

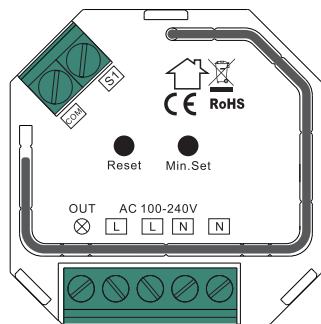

Zigbee to Triac Dimmer



Installationsanleitung für Smart Dimmer
Installation Manual for Smart Dimmer
Installatiehandleiding voor Smart Dimmer
Instructions d'installation pour variateur smart

V830002ZT0W

DE

SICHERHEITSHINWEISE

Die Installation und Inbetriebnahme, die Wartung, der Austausch sowie die Deinstallation darf nur durch eine qualifizierte Elektrofachkraft vorgenommen werden. Die landesspezifischen Elektorinstallationsvorschriften sind einzuhalten.

ACHTUNG! Vor der Installation ist die Sicherung auszuschalten und erst nach vollständiger Installation und Prüfung wieder einzuschalten. Stellen Sie sicher, dass bei der Montage und Verdrahtung von Leuchten oder Versorgungsgeräten keine Spannung anliegt. Der Dimmer muss entsprechend der Montageanleitung installiert werden. Jede unsachgemäße Verwendung oder Montageart kann die Sicherheit beeinträchtigen.

Bei einem Defekt des Gerätes kontaktieren Sie unbedingt und unverzüglich den Händler oder Hersteller.

Die Wartungshinweise sind unbedingt zu beachten. Das Eindringen von Feuchtigkeit ist zu vermeiden.

Die Montageanleitung ist aufzubewahren.

Technische Änderungen vorbehalten.

Informationen zur Deinstallation und Entsorgung entnehmen Sie unserer Website.

EN

SAFETY INSTRUCTIONS

Installation and commissioning, maintenance, replacement, and deinstallation must only be performed by a qualified electrician. National-specific electrical installation regulations must be followed.

WARNING! Before installation, the circuit breaker must be turned off and only turned on again after complete installation and inspection. Ensure there is no voltage present during the installation and wiring of luminaires or power supplies.

The dimmer must be installed according to the installation instructions. Any improper use or installation can compromise safety.

In case of device defect, contact the dealer or manufacturer immediately. Maintenance instructions must be strictly followed. The ingress of moisture must be avoided. The installation manual must be kept. Technical changes reserved.

For information on deinstallation and disposal, please refer to our website.

NL

VEILIGHEIDSIJNSTRUCTIES

Installatie en ingebruikname, onderhoud, vervanging en de-installatie mogen alleen worden uitgevoerd door een gekwalificeerde electricien. Land specifieke elektrotechnische installatieregels moeten worden gevolgd.

WAARSCHUWING! Voordat u begint met de installatie, moet de zekering worden uitgeschakeld en pas weer worden ingeschakeld na volledige installatie en inspectie. Zorg ervoor dat er tijdens de montage en bedrading van armaturen of voedingen geen spanning aanwezig is. De dimmer moet volgens de installatie-instructies worden geïnstalleerd. Elk onjuist gebruik of verkeerde installatie kan de veiligheid in gevaar brengen.

Bij een defect van het apparaat dient u onmiddellijk contact op te nemen met de dealer of fabrikant. Onderhoudsinstructies moeten strikt worden opgevolgd. Het binnendringen van vocht moet worden vermeden. De installatiehandleiding moet worden bewaard. Technische wijzigingen voorbehouden. Voor informatie over de-installatie en verwijdering, raadpleeg onze website.

FR

CONSIGNES DE SÉCURITÉ

L'installation et la mise en service, l'entretien, le remplacement ainsi que la désinstallation doivent être effectués uniquement par un électricien qualifié. Les réglementations nationales spécifiques à l'installation électrique doivent être respectées.

ATTENTION ! Avant l'installation, le disjoncteur doit être coupé et ne doit être réactivé qu'après une installation et une vérification complètes. Assurez-vous qu'aucune tension n'est présente lors du montage et du câblage des luminaires ou des alimentations.

Le variateur doit être installé conformément aux instructions de montage. Toute utilisation ou installation incorrecte peut compromettre la sécurité.

En cas de défaillance de l'appareil, contactez immédiatement le revendeur ou le fabricant. Les instructions d'entretien doivent être strictement suivies. L'intrusion d'humidité doit être évitée. Le manuel d'installation doit être conservé. Modifications techniques réservées.

Pour des informations sur la désinstallation et l'élimination, veuillez consulter notre site Web.

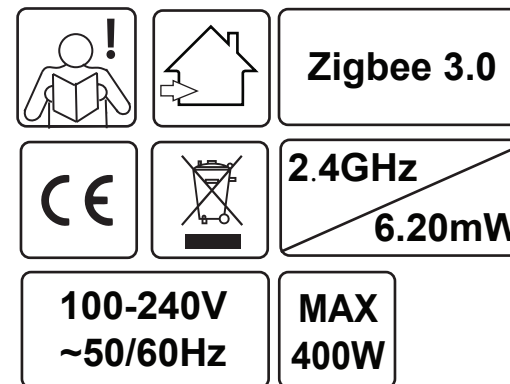

Hiermit erklärt die VYSN GmbH, dass der hier beschriebene Funkantagentyp der Richtlinie 2014/53/EU entspricht. Der vollständige Text der EU-Konformitätserklärung ist unter der folgenden Internetadresse verfügbar.

Hereby, VYSN GmbH declares that the radio equipment described here is in compliance with Directive 2014/53/EU. The full text of the EU declaration of conformity is available at the following website.

VYSN GmbH déclare par la présente que le type de dispositif radio décrit ici satisfait à la directive 2014/53/UE. Le texte complet de la déclaration de conformité UE est disponible à l'adresse Internet suivante.

Hiermee verklaart YSGmbH, dat het hier beschreven radiografische type voldoet aan de richtlijn 2014/53/EU. De volledige tekst van de EU-conformiteitsverklaring staat ter beschikking via het volgende internetadres.

Technische Modifikationen vorbehalten/
 Subject to technical modifications/
 Technische wijzigingen voorbehouden/
 Sous réserve de modifications techniques

🌐 vysn-group.com
 ✉ service@vysn-group.com

17.12.24/©VYSN GmbH/Siemensstr. 12/52525 Heinsberg



Zigbee to Triac Dimmer

Important: Read All Instructions Prior to Installation

Function introduction

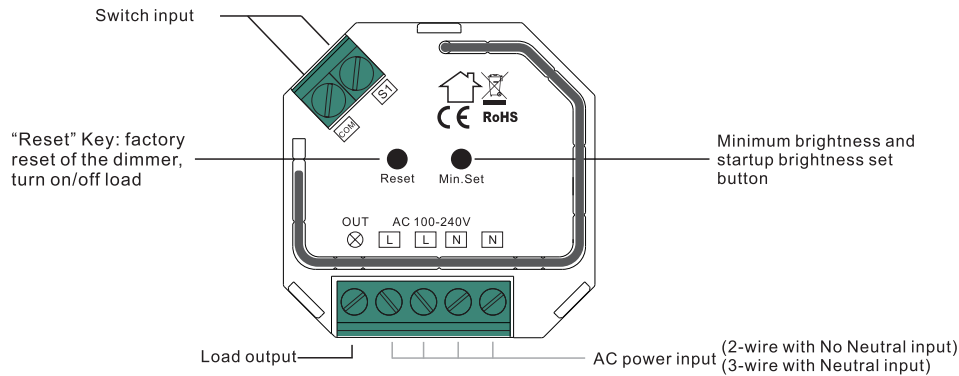

Product Data

Input Voltage	Output Voltage	Output Current	Size(LxWxH)
100-240VAC	100-240VAC	1.8A max	45.5x45x20.3mm

Compatible Load Types

Load Symbol	Load Type	Maximum Load	Remarks
	Dimmable LED lamps	200W @ 230V 100W @ 110V	Due to variety of LED lamp designs, maximum number of LED lamps is further dependent on power factor result when connected to dimmer.
	Dimmable LED drivers	200W @ 230V 100W @ 110V	Maximum permitted number of drivers is 200W divided by driver nameplate power rating.
	Incandescent lighting, HV Halogen lamps	400W @ 230V 200W @ 110V	
	Low voltage halogen lighting with electronic transformers	200W @ 230V 100W @ 110V	

ZigBee Clusters the device supports are as follows:

Input Clusters

- 0x0000: Basic
- 0x0003: Identify
- 0x0004: Groups
- 0x0005: Scenes
- 0x0006: On/off
- 0x0702: Simple Metering
- 0x0008: Level Control
- 0x0b04: Electrical Measurement
- 0x0b05: Diagnostics

Output Clusters

- 0x0019: OTA

- ZigBee AC phase cut dimmer based on latest ZigBee 3.0 protocol
- 100-240VAC wide input and output voltage
- Supports resistive loads, capacitive loads or inductive loads
- 1 channel output, up to 400W
- Input and output with screw terminals, safe and reliable
- Both leading edge version and trailing edge versions are available for choosing, preset by factory setting
- Enables to control ON/OFF and light intensity of connected light source
- ZigBee end device that supports Touchlink commissioning
- Can directly pair to a compatible ZigBee remote via Touchlink without coordinator
- Supports self-forming zigbee network without coordinator and add other devices to the network
- Supports find and bind mode to bind a ZigBee remote
- Supports zigbee green power and can bind max. 20 zigbee green power switches
- Compatible with universal ZigBee gateway products
- Mini Size, easy to be installed into a standard wall box
- Radio frequency : 2.4GHz
- Waterproof grade: IP20

Main Features:

- Can operate under two-wire connection with no neutral lead or three-wire connection with neutral lead
- Advanced microprocessor control
- Implemented algorithm of smart light source detection
- Active power and energy metering functionality
- Soft start function
- Innovative minimum dimming level and startup brightness setting function
- Works with various types of switches – momentary, toggle, three-way, etc.
- Active element: semiconductor electronic switch
- To be installed in wall switch boxes of dimensions allowing for installation, conforming to provisions of applicable regulations
- The Bypass is an extension unit

As a dimmer it operates under the following loads:

- Conventional incandescent and HV halogen light sources
- ELV halogen lamps and dimmable LED bulbs (with electronic transformers)
- MLV halogen lamps (with ferromagnetic transformers)
- Dimmable LED bulbs
- Dimmable compact fluorescent CFL tube lamps
- Supported dimmable light sources (power factor > 0.5) with minimal power of 3VA using the Bypass (depending on the type of load)

Trailing edge or leading edge dimming mode can be preset by factory setting to control following types of loads:

- "Trailing edge" for resistive loads
- "Trailing edge" for capacitive loads
- "Leading edge" for inductive loads

Note: factory default version is trailing edge.

Safety & Warnings

- DO NOT install with power applied to device.
- DO NOT expose the device to moisture.

Operation

1. Do wiring according to connection diagram correctly.

2. This ZigBee device is a wireless receiver that communicates with a variety of ZigBee compatible systems. This receiver receives and is controlled by wireless radio signals from the compatible ZigBee system.

3. Zigbee Network Pairing through Coordinator or Hub (Added to a Zigbee Network)

Step 1: Remove the device from previous zigbee network if it has already been added to, otherwise pairing will fail. Please refer to the part "Factory Reset Manually".

Step 2: From your ZigBee Controller or hub interface, choose to add lighting device and enter Pairing mode as instructed by the controller.

Step 4: Connected light will blink 5 times and then stay solid on, then the device will appear in your controller's menu and can be controlled through controller or hub interface.

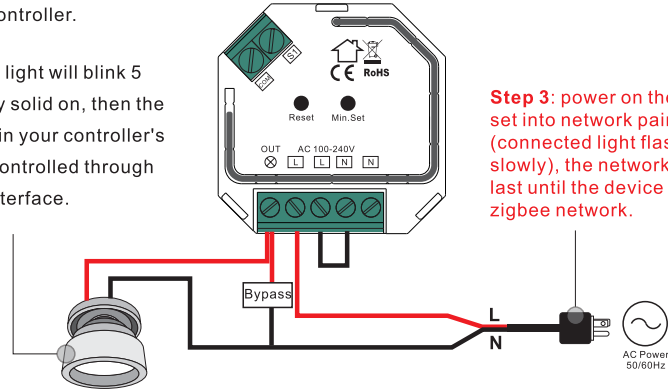

Step 3: power on the device, it will be set into network pairing mode (connected light flashes twice slowly), the network pairing mode will last until the device is added to a zigbee network.

4. TouchLink to a Zigbee Remote

Step 2: Bring the remote or touch panel within 10cm of the lighting device.

Step 3: Set the remote or touch panel into Touchlink commissioning, please refer to corresponding remote or touch panel manual to learn how.

Step 4: There shall be indication on the remote for successful link and connected light will flash twice.

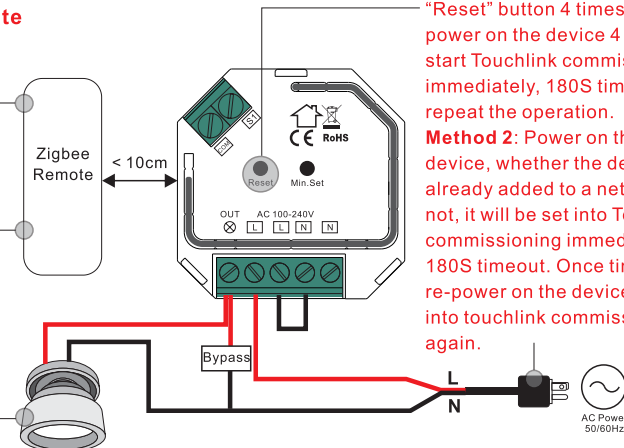

Step 1: Method 1: Short press "Reset" button 4 times (or re-power on the device 4 times) to start Touchlink commissioning immediately, 180S timeout, repeat the operation.
Method 2: Power on the device, whether the device is already added to a network or not, it will be set into Touchlink commissioning immediately, 180S timeout. Once timeout, re-power on the device to set it into touchlink commissioning again.

- Note:**
- 1) Directly TouchLink (both not added to a ZigBee network), each device can link with 1 remote.
 - 2) TouchLink after both added to a ZigBee network, each device can link with max. 30 remotes.
 - 3) To control by both gateway and remote, add remote and device to network first then TouchLink.
 - 4) After TouchLink, the device can be controlled by the linked remotes.

5. Removed from a Zigbee Network through Coordinator or Hub Interface

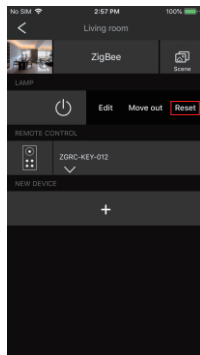

From your ZigBee controller or hub interface, choose to delete or reset the lighting device as instructed. The connected light blinks 3 times to indicate successful reset.

6. Factory Reset Manually

Note: All configuration parameters will be reset after the device is reset or removed from the network.

Step 2: Connected light will blink 3 times to indicate successful reset.

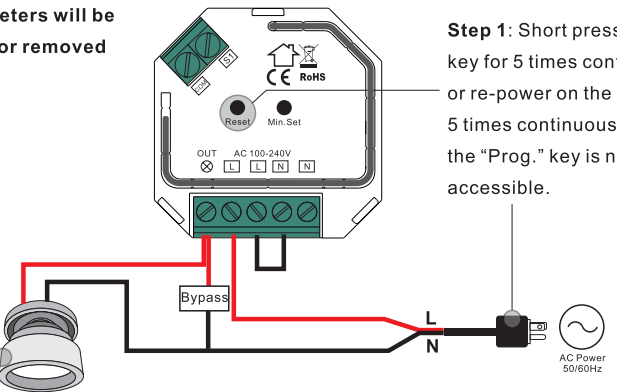

Step 1: Short press "Reset." key for 5 times continuously or re-power on the device for 5 times continuously if the "Prog." key is not accessible.

7. Factory Reset through a Zigbee Remote (Touch Reset)

Note: Make sure the device already added to a network, the remote added to the same one or not added to any network.

Step 2: Bring the remote or touch panel within 10cm of the lighting device.

Step 3: Set the remote or touch panel into Touch Reset procedure to reset the device, please refer to corresponding remote or touch panel manual to learn how.

Step 4: There shall be indication on the remote and connected light flashes 3 times for successful reset.

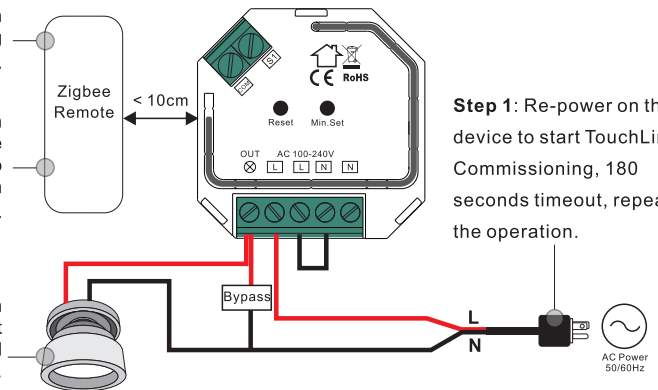

Step 1: Re-power on the device to start TouchLink Commissioning, 180 seconds timeout, repeat the operation.

8. Find and Bind Mode

Note: Make sure the device and remote already added to the same zigbee network.

Step 2: Set the remote or touch panel (target node) into find and bind mode, and enable it to find and bind initiator, please refer to corresponding remote or touch panel manual.

Step 3: There shall be indication on the remote or touch panel that it bind the device successfully and can control it then to learn how.

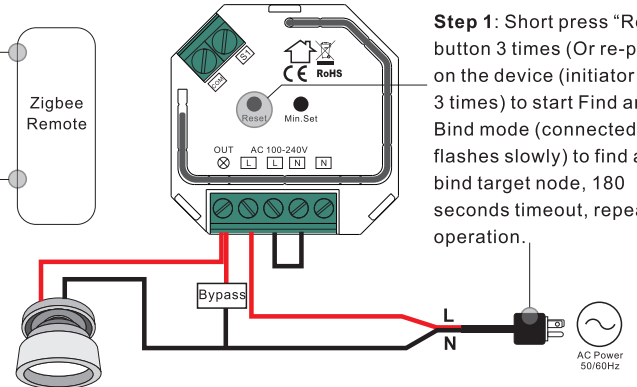

Step 1: Short press "Reset." button 3 times (Or re-power on the device (initiator node) 3 times) to start Find and Bind mode (connected light flashes slowly) to find and bind target node, 180 seconds timeout, repeat the operation.

9. Learning to a Zigbee Green Power Switch

Step 2: Set the green power switch into Learning mode, please refer to its manual.

Step 3: Connected light will flash twice to indicate successful learning. Then the switch can control the device.

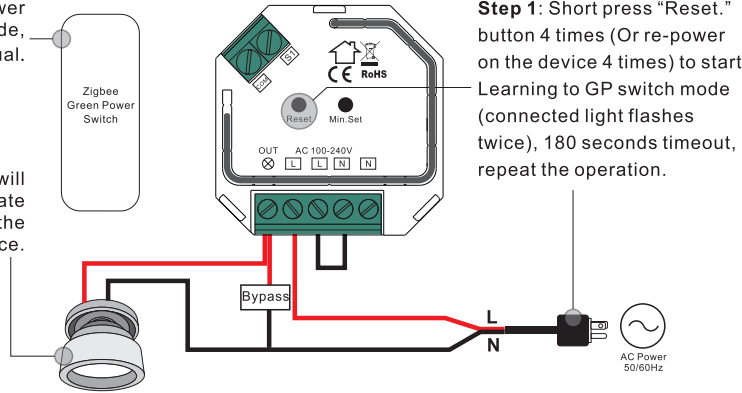

Step 1: Short press "Reset." button 4 times (Or re-power on the device 4 times) to start Learning to GP switch mode (connected light flashes twice), 180 seconds timeout, repeat the operation.

Note: Each device can learn to max. 20 zigbee green power remotes.

10. Delete Learning to a Zigbee Green Power Switch

Step 2: Set the paired green power switch into Learning mode, please refer to its manual.

Step 3: Connected light will flash 4 times to indicate successful deleting.

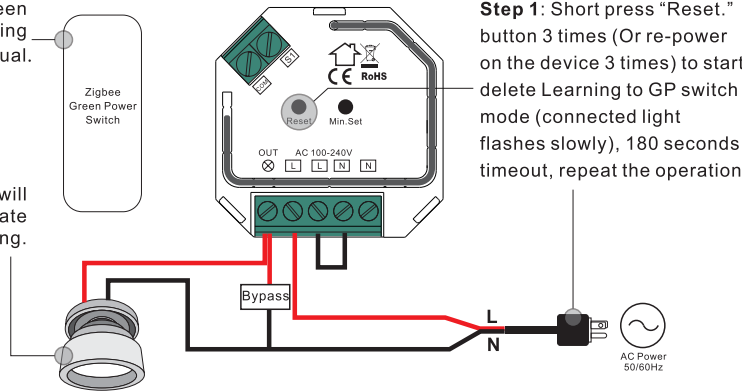

Step 1: Short press "Reset." button 3 times (Or re-power on the device 3 times) to start delete Learning to GP switch mode (connected light flashes slowly), 180 seconds timeout, repeat the operation.

11. Setup a Zigbee Network & Add Other Devices to the Network (No Coordinator Required)

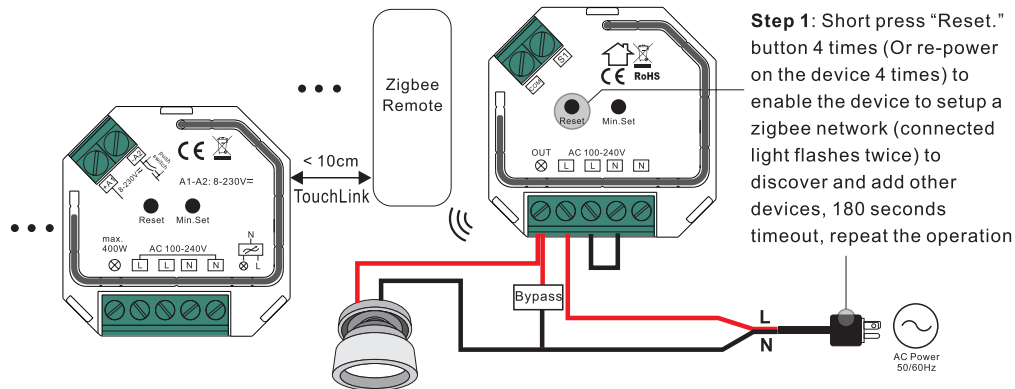

Step 1: Short press "Reset." button 4 times (Or re-power on the device 4 times) to enable the device to setup a zigbee network (connected light flashes twice) to discover and add other devices, 180 seconds timeout, repeat the operation.

Step 2: Set another device or remote or touch panel into network pairing mode and pair to the network, refer to their manuals.

Step 3: Pair more devices and remotes to the network as you would like, refer to their manuals.

Step 4: Bind the added devices and remotes through Touchlink so that the devices can be controlled by the remotes, refer to their manuals.

Note: 1) Each added device can link and be controlled by max. 30 added remotes.

2) Each added remote can link and control max. 30 added devices.

12. OTA

The device supports firmware updating through OTA, and will acquire new firmware from zigbee controller or hub every 10 minutes automatically.

13. Minimum and Startup Brightness Setting Button

Press and hold down the button for 3 seconds to set minimum brightness: when current brightness value is 1%-50%, it will be set as minimum brightness. When current brightness value is 100%, previously set minimum brightness will be deleted. Once a minimum brightness is set, the connected load can not be dimmed below this level.

Short press the button twice to set startup brightness: when current brightness value is 1%-50%, it will be set as startup brightness. When current brightness value is 0%, previously set startup brightness will be deleted.

Note: startup brightness setting function is to avoid the phenomenon that some dimmable LED drivers can not be turned on after dimmed to a low level and turned off. Once setting a startup brightness, if the startup brightness is higher than dimmed level before turned off, the driver will first go to the startup brightness after turned on then drop down to the dimmed level. If the startup brightness is lower than the dimmed level before turned off, the driver will directly go to the dimmed level after turned on.

14. Controlled by a push switch:

Once connected with a push switch, click the push switch to switch ON/OFF, press and hold down it to increase/decrease light intensity.

Wiring Diagram

Notes for the diagrams:

L - terminal for live lead

N - terminal for neutral lead

Out - output terminal of the dimmer (controlling connected light source)

S1 - terminal for switch

COM - terminal for grounding to the switch connected to the dimmer

Supported Switch Types:

The switch types this device supports can be configured by factory setting:

1. Push Switch (factory default setting)
2. Toggle On/Off Switch (can be configured by factory setting upon request)

Compatible load types and recommended values of power for supported loads:

Supported load types		100-240V~	
	Resistive loads Conventional incandescent and halogen light sources	20-400W @ 230V 20-200W @ 110V	
	Capacitive loads Fluorescent tube lamp (compact / with electronic ballast), electronic transformer, LED	Using Bypass: 3-200W @ 230V 3-100W @ 110V	No Bypass Used: 20-200W @ 230V 20-100W @ 110V
		Inductive loads Ferromagnetic transformers	
		20-200W @ 230V 20-100W @ 110V	

(1) 2-Wire Connection With No Neutral Lead

With PUSH LV

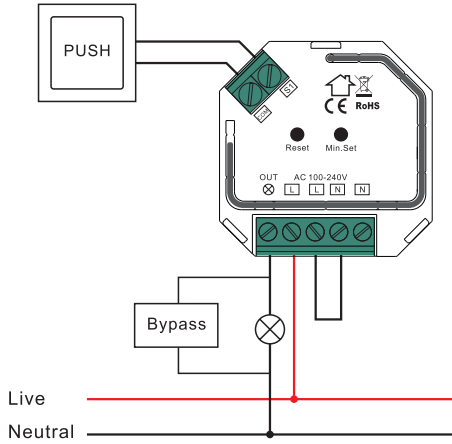

With PUSH

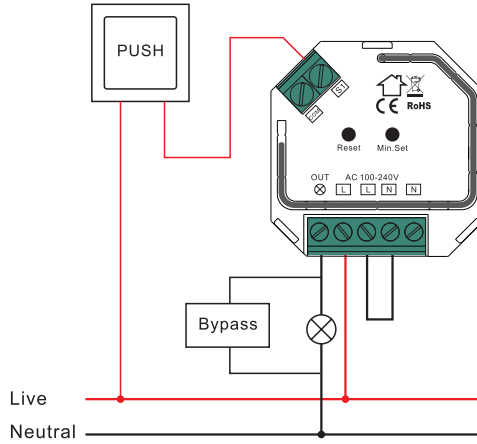

NOTE: Switch connected to the S1 terminal activates the basic functionality of the dimmer (turning the light on/off, dimming).

The Bypass is a device designed to work with the micro smart dimmer. It should be used in case of connecting LED bulbs or energy saving compact fluorescent lamps. The Bypass prevents flickering of the LED lights and glowing of the turned off compact fluorescent lamps. In the case of 2-wire connection, the Bypass allows to reduce minimum power of load required by the dimmer for correct operation. The Bypass provides powering of the dimmer in case of controlling the low loads of minimum power down to 3W (for $\cos\phi > 0.5$).

(2) 3-Wire Connection With Neutral Lead

With PUSH LV

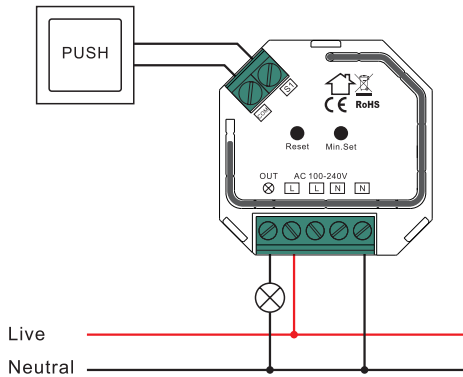

With PUSH

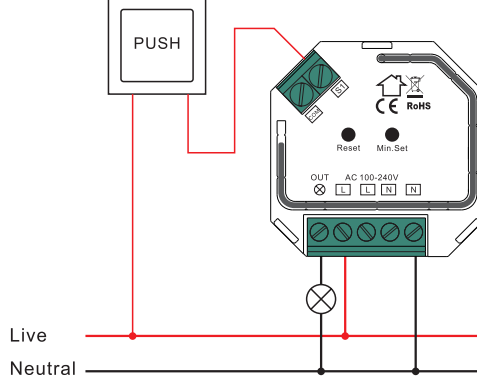

NOTE: Switch connected to the S1 terminal activates the basic functionality of the dimmer (turning the light on/off, dimming).

(3) Multiple Momentary or Push Switches Connection

With PUSH LV

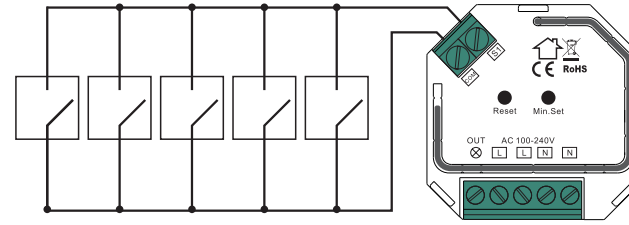

With PUSH

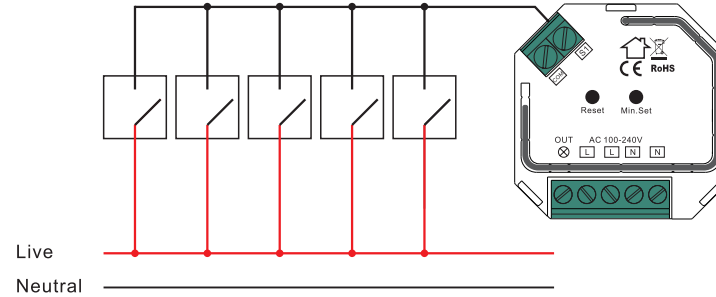

This phase dimmer adopts leading edge dimming (forward phase control) or trailing edge dimming (reverse phase control), two versions are available for choosing, factory default version is trailing edge. Please make sure the connected loads support the control type you choose. Please refer to the user manual of the load or consult the supplier of the load.

DE-Entsorgung (Europäische Union)

Bitte das Produkt nicht über den Hausmüll entsorgen! Produkte, die mit diesem Symbol gekennzeichnet sind, müssen gemäß der WEEE-Richtlinie für Elektro- und Elektronik-Altgeräte über lokale Sammelstellen für Elektroschrott entsorgt werden. Altbatterien und Akkus, die nicht fest im Gerät verbaut sind, sowie Lampen, die sich zerstörungsfrei entnehmen lassen, sind vor der Abgabe an eine Sammelstelle vom Gerät zu trennen. Händler sind gesetzlich verpflichtet, Altgeräte vom Endnutzer zurückzunehmen. Alternativ kann das Altgerät an folgende Adresse geschickt werden:

VYSN GmbH, Siemensstraße 12, 52525 Heinsberg



EN-Disposal (European Union)

Please do not dispose of the product with household waste! Products marked with this symbol must be disposed via local e-waste collection points in accordance with the WEEE Directive for Waste Electrical and Electronic Equipment. Used batteries and accumulators that are not permanently installed in the device, as well as lamps that can be removed without being destroyed, must be separated from the device before being handed over to a collection point. Dealers are legally obliged to take back old devices from the end user. Alternatively, the old device can be sent to the following address:

VYSN GmbH, Siemensstraße 12, 52525 Heinsberg



NL - informatie over recycling (Europese Unie)

Gooi het product niet weg met het huishoudelijk afval! Producten gemarkeerd met dit symbool moeten worden afgevoerd via plaatselijke inzamelpunten voor elektronisch afval in overeenstemming met de WEEE-richtlijn voor afgedankte elektrische en elektronische apparatuur. Gebruikte batterijen en accu's die niet permanent in het apparaat zijn geïnstalleerd, evenals lampen die kunnen worden verwijderd zonder te worden vernietigd, moeten van het apparaat worden gescheiden voordat ze worden ingeleverd bij een inzamelpunt. Dealers zijn wettelijk verplicht oude apparaten terug te nemen van de eindgebruiker. Als alternatief kan het oude apparaat naar het volgende adres worden verzonden:

VYSN GmbH, Siemensstraße 12, 52525 Heinsberg



FR-informations sur le recyclage (Union européenne)

Veillez ne pas jeter le produit avec les ordures ménagères ! Les produits marqués de ce symbole doivent être éliminés via les points de collecte des déchets électroniques locaux conformément à la directive DEEE relative aux déchets d'équipements électriques et électroniques. Les piles et accumulateurs usagés qui ne sont pas installés de manière permanente dans l'appareil, ainsi que les lampes qui peuvent être retirées sans être détruites, doivent être séparés de l'appareil avant d'être remis à un point de collecte. Les revendeurs sont légalement tenus de reprendre les anciens appareils de l'utilisateur final. Alternativement, l'ancien appareil peut être envoyé à l'adresse suivante :

VYSN GmbH, Siemensstraße 12, 52525 Heinsberg



Points de collecte sur www.quefairede mesdechets.fr
Privilégiez la réparation ou le don de votre appareil !

IT-informazioni sul riciclaggio (Unione Europea)

Si prega di non smaltire il prodotto con i rifiuti domestici! I prodotti contrassegnati con questo simbolo devono essere smaltiti tramite i punti di raccolta locali dei rifiuti elettronici in conformità con la Direttiva RAEE per i rifiuti di apparecchiature elettriche ed elettroniche. Le batterie e gli accumulatori usati che non sono installati in modo permanente nell'apparecchio, nonché le lampade che possono essere rimosse senza essere distrutte, devono essere separati dall'apparecchio prima di essere consegnati a un punto di raccolta. I rivenditori sono legalmente obbligati a riprendere i vecchi dispositivi dall'utente finale. In alternativa è possibile spedire il vecchio dispositivo al seguente indirizzo:

VYSN GmbH, Siemensstraße 12, 52525 Heinsberg



ES-información sobre reciclaje (Unión Europea)

¡No deseche el producto con la basura doméstica! Los productos marcados con este símbolo deben eliminarse a través de puntos locales de recolección de desechos electrónicos de acuerdo con la Directiva WEEE para desechos de equipos eléctricos y electrónicos. Las pilas y acumuladores usados que no estén instalados permanentemente en el aparato, así como las lámparas que puedan retirarse sin destruirse, deben separarse del aparato antes de entregarse en un punto de recogida. Los distribuidores están obligados legalmente a recuperar los dispositivos viejos del usuario final. Alternativamente, el dispositivo antiguo se puede enviar a la siguiente dirección:

VYSN GmbH, Siemensstraße 12, 52525 Heinsberg



DA-Bortskaffelse (EU)

Bortskaf ikke produktet sammen med husholdningsaffaldet! Produkter mærket med dette symbol skal bortskaffes via lokale indsamlingssteder for elektronisk affald i overensstemmelse med WEEE-direktivet for affald af elektrisk og elektronisk udstyr. Brugte batterier og akkumulatører, der ikke er fast installeret i apparatet, samt lamper, der kan fjernes uden at blive ødelagt, skal adskilles fra apparatet, inden det afleveres til et indsamlingssted. Forhandlere er juridisk forpligtet til at tage gamle enheder tilbage fra slutbrugeren. Alternativt kan den gamle enhed sendes til følgende adresse:

VYSN GmbH, Siemensstraße 12, 52525 Heinsberg



PL - Utylizacja (Unia Europejska)

Prosimy nie wyrzucać produktu razem z odpadami domowymi! Produkty oznaczone tym symbolem należy utylizować w lokalnych punktach zbiórki elektroodpadów zgodnie z dyrektywą WEEE dotyczącą zużytego sprzętu elektrycznego i elektronicznego. Zużyte baterie i akumulatory, które nie są zamontowane na stałe w urządzeniu, a także lampy, które można wyjąć bez zniszczenia, należy oddzielić od urządzenia przed oddaniem do punktu zbiórki. Dealerzy są prawnie zobowiązani do odbioru starych urządzeń od użytkownika końcowego. Alternatywnie stare urządzenie można wysłać na adres:

VYSN GmbH, Siemensstraße 12, 52525 Heinsberg



RU - Утилизация (Европейский Союз)

Пожалуйста, не выбрасывайте изделие вместе с бытовыми отходами! Продукты, отмеченные этим символом, должны утилизироваться через местные пункты сбора электронных отходов в соответствии с Директивой WEEE об отходах электрического и электронного оборудования. Исползованные батарейки и аккумуляторы, не установленные в устройстве стационарно, а также лампы, которые можно снять без разрушения, перед сдачей в пункт приема необходимо отделить от устройства. Дилеры по закону обязаны забрать старые устройства у конечного пользователя. Альтернативно старое устройство можно отправить по следующему адресу:
VYSN GmbH, Siemensstraße 12, 52525 Heinsberg



SW - Avfallshantering (Europeiska unionen)

Vänligen släng inte produkten med hushållsavfallet! Produkter märkta med denna symbol måste kasseras via lokala insamlingsställen för e-avfall i enlighet med WEEE-direktivet för avfall från elektrisk och elektronisk utrustning. Förbrukade batterier och ackumulatörer som inte är permanent installerade i enheten, samt lampor som kan tas bort utan att förstöras, ska separeras från enheten innan de lämnas till en insamlingsplats. Återförsäljare är enligt lag skyldiga att ta tillbaka gamla enheter från slutanvändaren. Alternativt kan den gamla enheten skickas till följande adress:

VYSN GmbH, Siemensstraße 12, 52525 Heinsberg



TR - Bertaraf (Avrupa Birliği)

Lütfen ürünü ev atıklarıyla birlikte atmayın! Bu sembolle işaretlenen ürünler, Atık Elektrikli ve Elektronik Ekipmanlara ilişkin WEEE Direktifine uygun olarak yerel e-atık toplama noktaları aracılığıyla imha edilmektedir. Cihazı kalıcı olarak takılmayan kullanılmış piller ve akümülatörler ile imha edilmeden çıkarılabilen lambalar, bir toplama noktasına teslim edilmeden önce cihazdan ayrılmalıdır. Bayiler yasal olarak eski cihazları son kullanıcıdan geri almakla yükümlüdür. Alternatif olarak eski cihaz aşağıdaki adrese gönderilebilir:

VYSN GmbH, Siemensstraße 12, 52525 Heinsberg



HU - Ártalmatlanítás (Európai Unió)

Kérjük, ne dobja ki a terméket a háztartási hulladékkal együtt! Az ezzel a szimbólummal jelölt termékeket az elektromos és elektronikus berendezések hulladékaira vonatkozó WEEE-irányelvnek megfelelően a helyi e-hulladék-gyűjtőhelyeken kell leadni. A készülékbe nem tartósan beszerelt használt elemeket és akkumulátorokat, valamint a tönkremenetel nélkül eltávolítható lámpákat a gyűjtőhelyre történő átadás előtt le kell választani a készülékről. A kereskedőknek törvényi kötelezettségük van a régi készülékek visszavételére a végfelhasználótól. Alternatív megoldásként a régi készüléket elküldheti a következő címre:

VYSN GmbH, Siemensstraße 12, 52525 Heinsberg

